

Removable/Fixed Bollard Power Shield [PS-50-K4]



Bollard

Removable/Fixed Power Shield [PS-50-K4] bollard systems used to protect the perimeter and divert the vehicle.

Easy Maintenance

The arrangement of the components makes maintenance easier. The main components are accessible from above for inspection or replacements without having to remove the bollard from the ground.

Benefits of Bollard

Some of the benefits of Bollards are explained below :

- ▶ Safety & protection for sensitive area.
- ▶ Ease of Installation.
- ▶ Strength and Durability.
- ▶ Reliable and Dependable.
- ▶ Bollards are Cost-Effective.
- ▶ Aesthetically acceptable.

Optional Accessories

LED on head.

Designed according to



The bollard is a device commonly used to protect sensitive area or vehicle parking. The Removable/Fixed Power Shield [PS-50-K4] bollard were conceived with the purpose of maximizing safety in all areas that may be threatened by vehicles. It provide an innovative answer to protecting sensitive buildings, squares, market, pedestrian areas and places with high traffic.

- Removable cylinder to allow temporary access
- Interchangeable protective cover so that the bollard is always just like new.
- Designed according to PAS 68; IWA 14-1 and ASTM F2656 standards. Able to withstand impact with a truck driven at 48Km/h. P1 penetration rating.
- "Shallow Mounted" design : minimum hole depth required

Application Areas



Government
Institutions



Commercial
Areas



Financial
Institutions



Airport
Premises



Business Office
Centers



Hotels



Sports
Complexes



Recreational
Areas

Removable/Fixed Bollard Power Shield [PS-50-K4]

Installation Details

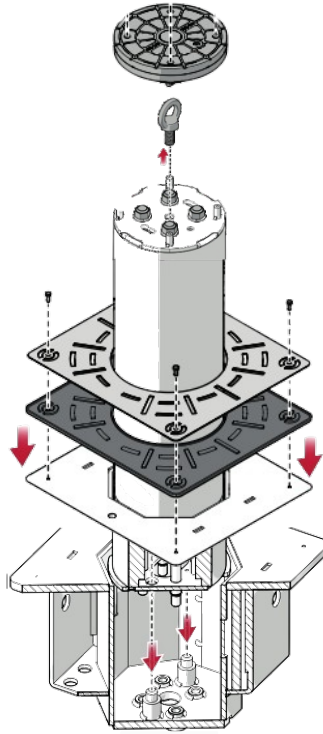

Technical Specification

Make	NEPTUNE
Model	Power Shield [PS-50-K4] INOX (Removable/Fixed)
Cylinder height from ground	1000 MM
Cylinder diameter	275 MM
Cylinder treatment	Hot dip galvanized
Protective cover type	AISI 304 stainless steel
Reflective strip height	55 MM
Standard reflecting strip colour	Yellow
Head material type	Aluminum
Head treatment type	Powder coated
Cylinder wall thickness	18 MM
Type of use	Perimeter security
Break in resistance	673,000 J
Weight of underground base	100 KG
Traffic Bollard Weight	120 KG



CORPORATE OFFICE:
NEPTUNE AUTOMATIC PVT. LTD.
 Neptune House, A -11, Sector-59,
 Noida, Uttar Pradesh-201301, India
Tel :+91 120 420 5900, 429 7900
Web:www.neptuneautomatic.com



Sales:
 +91 9555 500 300
 connect@neptuneautomatic.com



Technical Support:
 +91 9311 123 300
 customercare@neptuneautomatic.com

LET'S CONNECT ON SOCIAL MEDIA

PRODUCT LAUNCH, NEW FEATURES, EVENTS



Linked in



Facebook