

# Automatic Barrier

## PowerLite X5



### Top Features

1. High torque bi-direction 24VDC BLDC motor for heavy and continuous traffic.
2. Boom arm is made of extruded aluminium alloy in telescopic boom with rubber gasket at bottom.
3. Telescopic boom offers flexibility in adjusting boom length as per site requirement.
4. Maximum supporting boom length is 6 mtr.
5. In-built encoder offers smooth & low noise operation e-configurable smooth movement & safety feature.
6. Reverse on contact obstacle detection safety standard.
7. Barrier housing made of 2 mm thick galvanized further reinforced load carrying area of motor mounting.
8. Programmable opening and closing speed.
9. Programmable deceleration during opening and closing or smooth landing with jerk.
10. Programmable motor force as per boom arm length and load.
11. Version available for left and right hand.
12. Modern design with removable top cover.

### Optional Accessories

1. Photocell
2. Loop detector
3. Fixed support



Neptune PowerLite X5 Barrier is a high speed automatic electro-mechanical barrier with 100% duty cycle, it is specially designed with suitable motor and mechanism to take load of boom arm up to 6 mtr. telescopic boom.

The powerful 24VDC 100 watt brushless DC drive unit performs flawlessly even in the most demanding operating and weather conditions. PowerLite X5 automatic barrier is a perfect product for medium traffic application.

## Application Areas



Government  
Institutions



Commercial  
Areas



Financial  
Institutions



Airport  
Premises



Business Office  
Centers



Hotels



Sports  
Complexes



Recreational  
Areas

# Automatic Barrier PowerLite X5

## Installation D tail

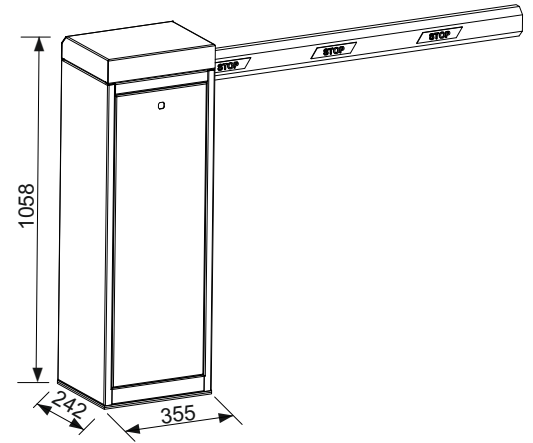
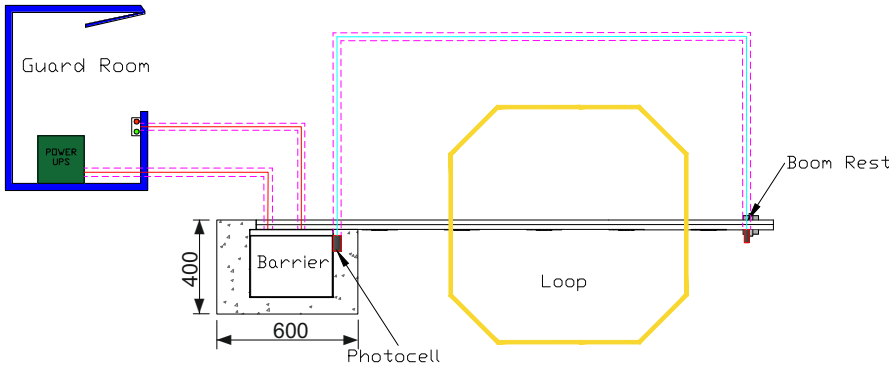

| LEGEND |                   |
|--------|-------------------|
|        | 25 MM PVC Conduit |
|        | Photo cell        |
|        | Boom Rest         |
|        | Push Button       |
|        | 3 Core 1.5 sq mm  |
|        | 2 Core 1 sq mm    |
|        | 1 Core 1.5 sq mm  |

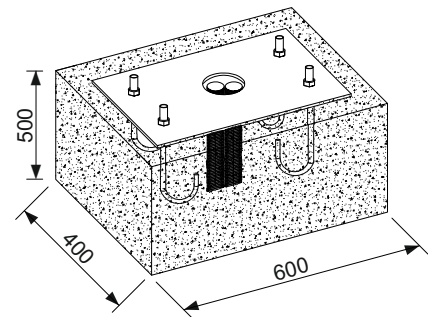

## Technical Characteristics

|                         |   |
|-------------------------|---|
| Make                    | Neptune                                   |
| Model                   | PowerLite X5                              |
| Power supply            | 220 - 240V AC ~50/60 Hz                   |
| Electric motor          | 24V DC brushless                          |
| Max. power              | 100 watt                                  |
| Max. torque             | 200 Nm (Max.)                             |
| Opening/closing speed   | 1.8 to 5 sec.                             |
| Surface treatment       | Pre hot dip galvanized and dust painted   |
| Encoder                 | Integrated with motor                     |
| Beam type               | Elliptical with rubber gasket and plastic |
| Protection class        | IP 65                                     |
| Use frequency           | 100 %                                     |
| Ambient temperature     | -30~60°C                                  |
| Relative humidity       | 95%                                       |
| Operation Life          | 10 million cycle                          |
| Remote control distance | ~30 mtr.                                  |
| Height of boom          | 900 mm from centre                        |
| Output for LED          | 12V 5Amp.                                 |
| Max. boom length        | 6 mtr. (Telescopic)                       |
| Certification           | CE  |



**CORPORATE OFFICE:**  
**NEPTUNE AUTOMATIC PVT. LTD.**  
 Neptune House, A-11, Sector 59,  
 Noida, Uttar Pradesh-201301, India  
 Tel: +91 120 420 5900, 429 7900  
 Web : www.neptuneautomatic.com

 Sales:  
 +91 9555 500 300  
 connect@neptuneautomatic.com

 Technical Support:  
 +91 9311 123 300  
 customercare@neptuneautomatic.com

LET'S CONNECT ON SOCIAL MEDIA EVENTS



 Linked in



 Instagram



 Facebook